



PD6000E

AGITATION TANK

PENNDRILL MANUFACTURING
321 ARBOR COURT
WINCHESTER, VA 22602

FOR MORE INFORMATION:
TOLL FREE: (866) 459-5309
OFFICE: (540) 771-5882
FAX: (540) 665-5206

WHY USE A PD600E AGITATION TANK?

The Agitation Tank has a paddle style mixer that can be used for mixing cement, bentonite and other similar slurries. It is most commonly used as a holding tank in colloidal batching systems. The tank and drive can be sized to suit the customer's specific requirements. Colloidal mixers can be added to this mixer as required to increase the speed of mixing and greatly improve the quality of the mix.



SPECIFICATIONS:

- CAPACITY: 6,000 LITER (1585 GALLON)
- DIMENSIONS: 8'-4" x 8'-4" x 7'-9"
- Electric Drive Gearbox
- Bottom Sweeping Paddle
- Multiple Inlets
- Multiple Discharges
- Large Clean-out Door
- Forklift Pockets & Lifting Eyes

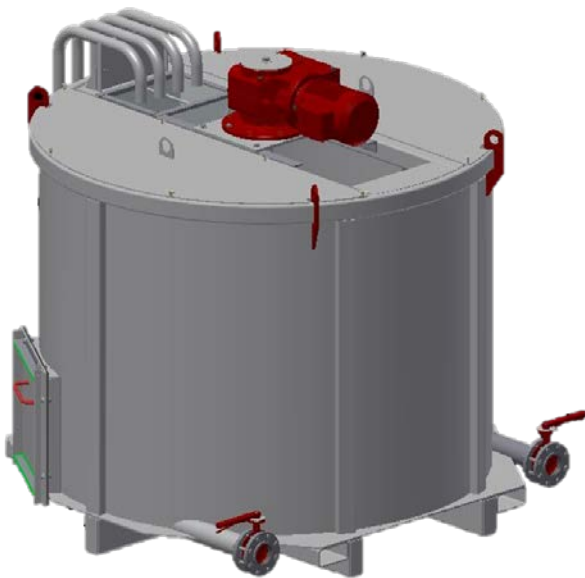

PENNDRILL MAINTAINS ALL COMMON WEAR
ITEM REPLACEMENT PARTS IN STOCK

